



Rich Learning Tasks

Dr. Marian Small



Problem Solving and Reasoning

Name:

15 Blocks

Number

You can represent a number using exactly 15 base ten blocks.
What could the number be?

Name:

Number

Getting Change

You have bought a gift for your sister. You paid £10 and received 3 coins and a note in change.

How much could the gift have cost?

How many possibilities can you find?

Name:

We Belong Together

Below are three groups of shapes. Decide what properties the shapes have in common within each group.

Draw two more shapes that could also belong in the group and explain why.

If you can think of more than one reason why the shapes belong together, draw two more shapes that belong with them.

Now draw your own group of five shapes that don't all look the same, but belong together and explain why.

Group 1

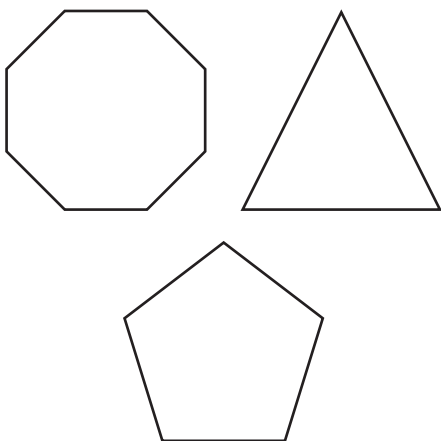

Group 2

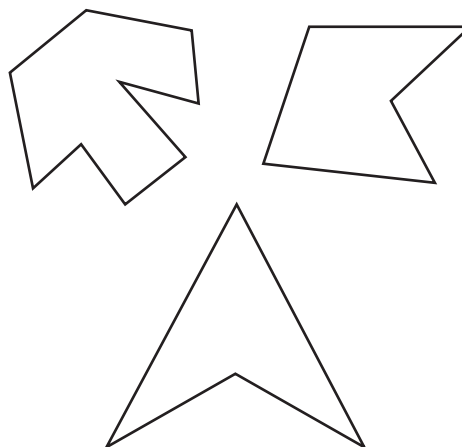

Group 3

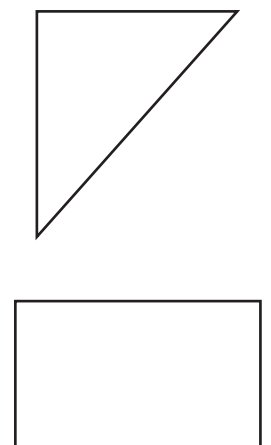

Name:

Two Triangles

One triangle is a LOT taller than another, but they have the same perimeter.

What is that perimeter and what do the triangles look like?

Did the size of the perimeter affect what you created? Explain.

Clocks

Draw hands to set the first clock to a start time where both hands are in the yellow part of the clock.

Draw hands to set the second clock to an end time where both hands are in the pink part of the clock.

Calculate how much time has passed between the first time and the second time.

Repeat with at least two different times.

START

END

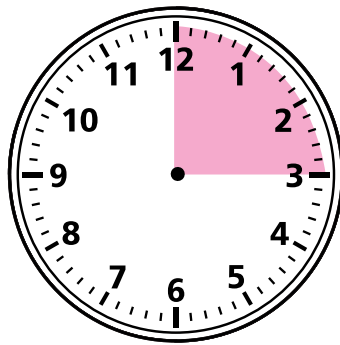
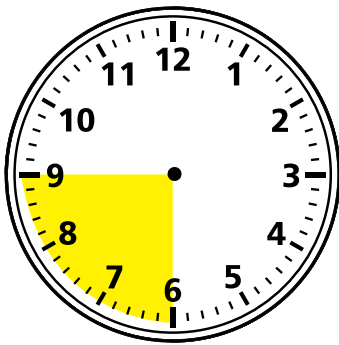
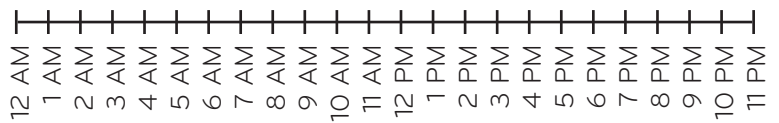
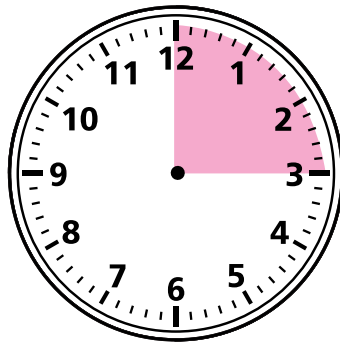
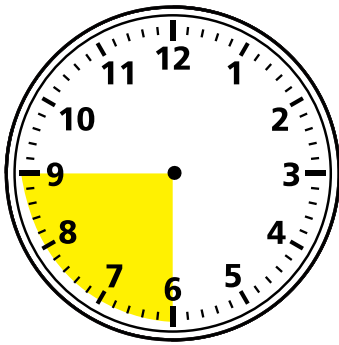
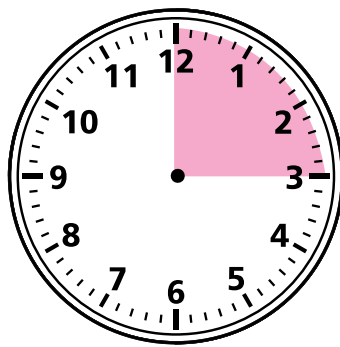
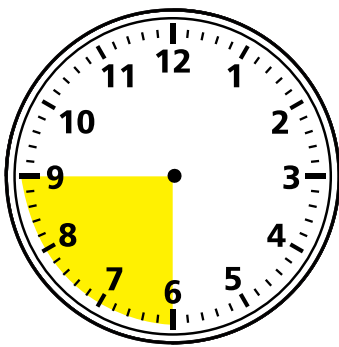

Name:

Balancing Act

All of the yellow boxes hold the same number of cans.

All of the blue boxes hold the same number of cans.

How many cans could be in each colour of box?

How do you know?

Think of lots of possibilities.

How are the number of cans in the two colours of boxes related?

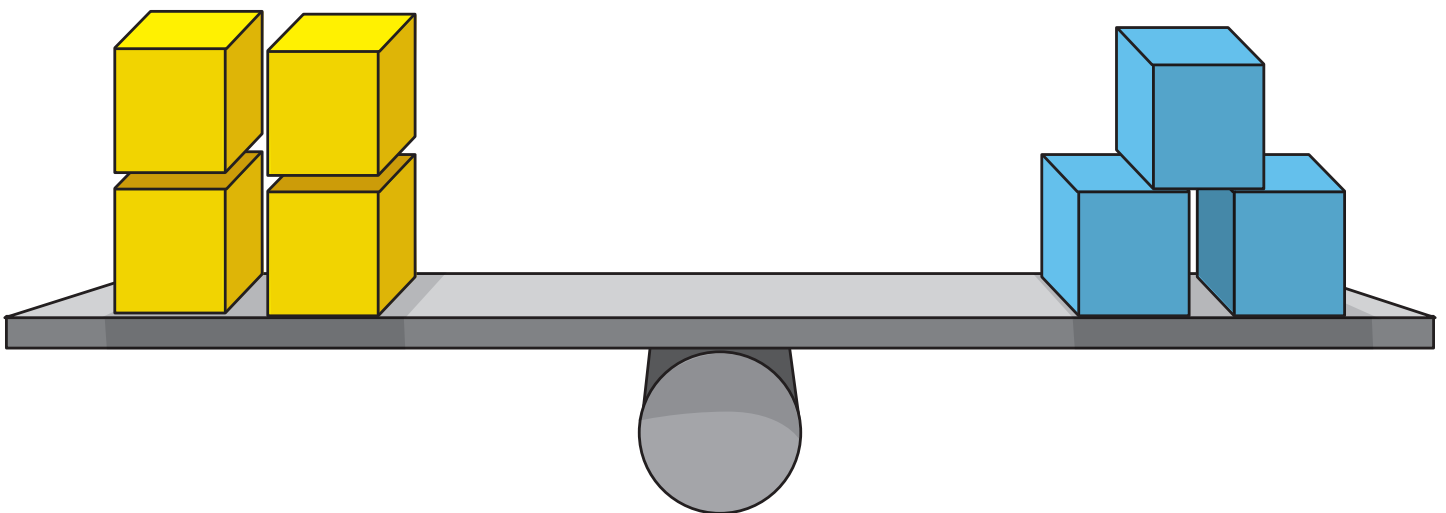

Name:

Circle Patterns

Here is the start of an increasing pattern. It has 2 circles and then 5 circles.

Continue growing the pattern until the 10th picture.

Do it lots of ways, making a different pattern each time.



Picture 1

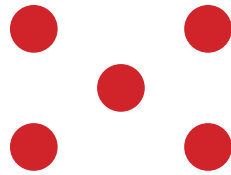

Picture 1

Picture 3

Name: _____

Sort Us

Use the numbers below.

How can you sort them so this graph shows how the 10 numbers were sorted?

How could you sort them to get this graph?

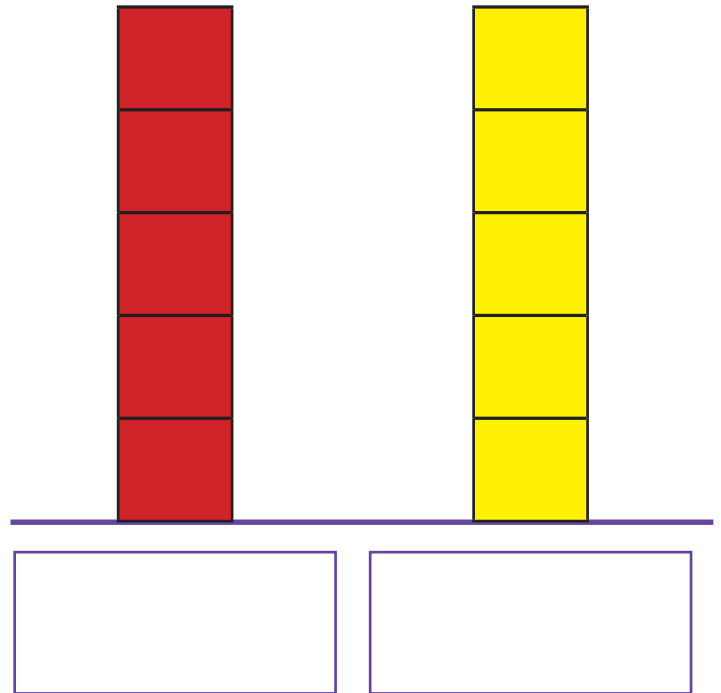
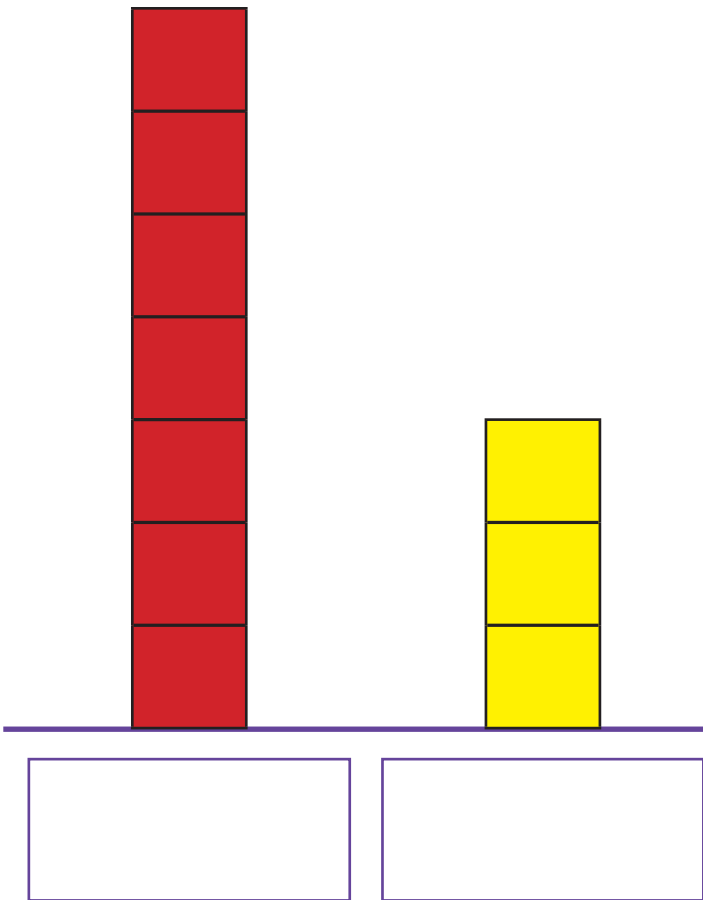

40

121

12

31

9

50

13

220

500

306